

TG17A、TG19投光灯 SPOT LIGHT

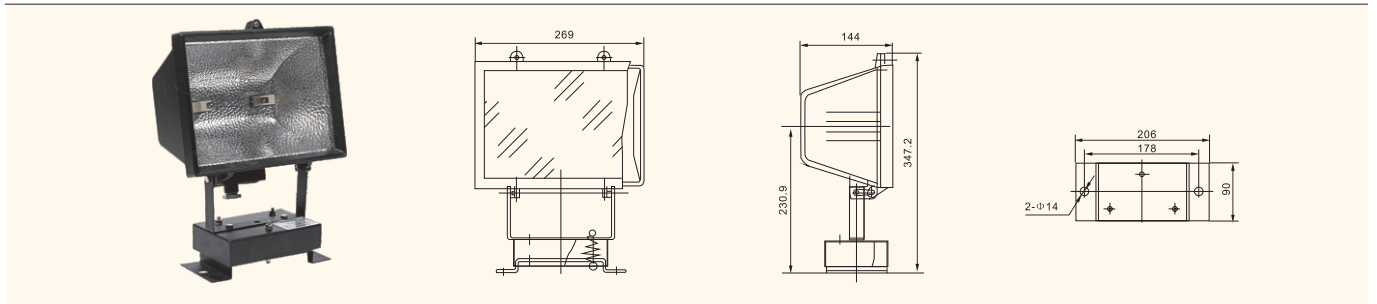

适用范围 The scope

适用于各种船舶、码头、船坞、广场及隧道照明。
Fit for illumination of ship, charf, dock, plaza and tunnel.

产品特点 Products characteristic

- 灯体采用铝精密压铸而成，粉末涂层，阳极化处理的高纯度铝质反射器，灯罩采用透明钢化玻璃。
 - 灯体密封性能好，防腐性强，壳体向上90°，向下45°调节。
1. The light body adopts aluminium exact die-casting, powder coat, high-purity aluminum reflector of anodic disposal, the lampshade adopts transparent toughened glass.
2. The light body has the good sealed function, intensity corrosive-resisting, the shell can adjust upside 90°, down 45°.

规格 Specification

型号 Type	电压 Voltage	功率 Power	灯头 Lamp Holder	光源 Illuminant	光通量LM luminous Flux	材料 Material	防护等级 Protection class	重量 Weight	附件 Annex
TG17A	110V/60Hz 220V/50Hz 220V/60Hz	200W	R7s	卤钨灯 Tungsten Halogen Light	3300	铝 Aluminium	IP56	4kg	—
		300W			4800				
		500W			8500				

IMPA CODE: 791823 / 791824

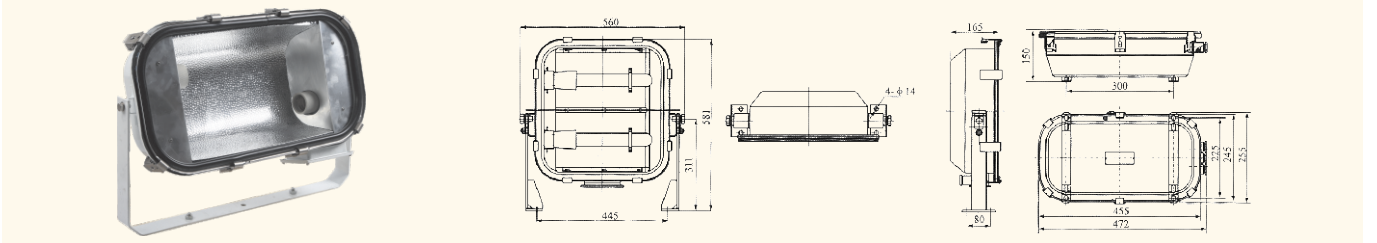

适用范围 The scope of application

适用于各类船舶、船坞、港口码头、堆货场和体育场等露天场所作投光照明用。
Fit for projecting illumination in outdoor place shch as ship,dock pork,storeplace and stadium.

产品特点 Products characteristic

- 选用优质不锈钢制造而成，灯罩为钢化玻璃，高纯度铝质反光镜，反光效果好；
 - 外观结构紧凑、美观、体积小。密封性能好，防腐性强，向上90°，向下45°角度调节。
1. Made of good stainless steel, the lampshade is made of toughened glass, and high-purity aluminum reflector, it has good reflecting effect.
2. Has compact structure and beauty appearance, small volume. Has fine seal function and anticorrosive performance, adjust angle upside 90°, down 45°.

产品认证 Production authentication

- 经中国船级社“CCS”型式认证；
 - 符合国际IEC规范和国家标准GB7000.7-2005；
 - 符合《钢质海船入级规范》；
1. Approved by the CCS(China Classification Society).
2. Conform to International IEC Norm and National standard GB7000.7-2005.
3. Conform to GRADE ENTRY NORMS FOR STEEL SHIPS.

规格 Specification

型号 Type	电压 Voltage	功率 Power	光通量lm Luminous flux	光源 Illuminant	电缆外径 Cable outside diameter	灯座 Lamp holder	防护等级 Protection class	重量 Weight	附件 Annex
TG19	220V/50Hz 220V/60Hz 110V/60Hz	2 × 250W	26000	高压钠灯 High-pressure sodium lamp	Φ12 ~ Φ14	E40	IP56	14.5kg	镇流器箱 ballast-box
		2 × 400W	47000						
		2 × 250W	20500	金属卤化物灯 metal halide lamp					
		2 × 400W	36000						