

船用尼龙水密插头、插座及开关、接线盒
MARINE NYLON WATERTIGHT PLUG, SOCKET, SWITCH AND JUNCTION BOX

电压Voltage:250V
防护等级Protection class : IP56
电缆外径Outside diameter: $\phi 14-\phi 16$

型号Type	CTF2-1、CTF2-2、CTF2-3、 CTF3-1、CTF3-2
--------	----------------------------------------

重量Weght	0.1kg、0.11kg、0.12kg、0.11kg、 0.13kg
---------	---------------------------------------

额定电压Rated Voltage 250V、250V、125V、500V、500V



型号Type	CZF2-1、CZF2-2、CZF2-3、 CZF3-1、CZF3-2
--------	----------------------------------------

重量Weght	0.2kg、0.21kg、0.21kg、0.21kg、 0.22kg
---------	---------------------------------------

额定电压Rated Voltage 250V、250V、125V、500V、500V

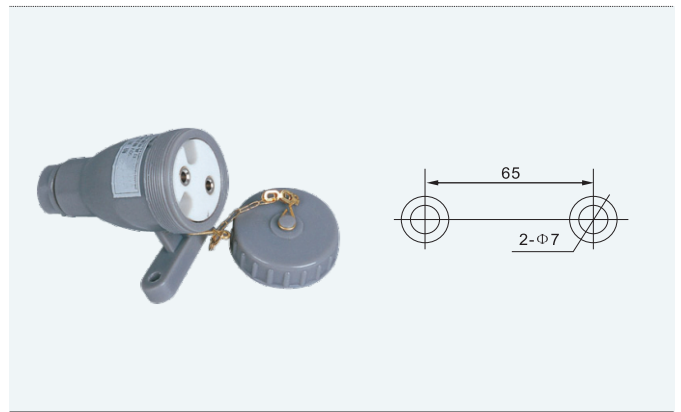

型号Type	CZKF2-2、CZKF2-3、CZKF3-2
--------	-------------------------

重量Weght	0.45kg、0.44kg、0.46kg
---------	----------------------

额定电压Rated Voltage 250V、250V、500V

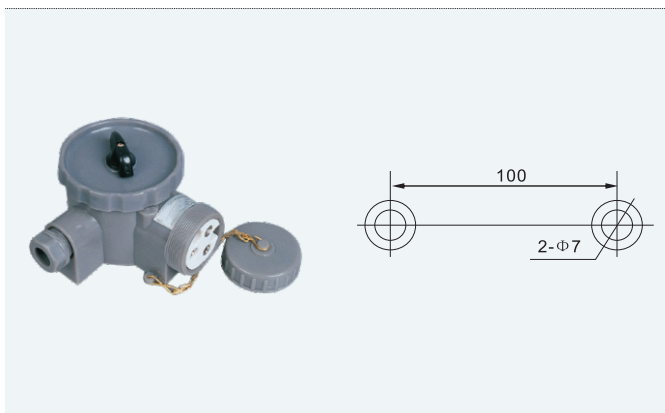

型号Type	CZKF2-4、CZKF2-5
--------	-----------------

重量Weght	0.5kg、0.45kg
---------	--------------

额定电压Rated Voltage 250V、125V

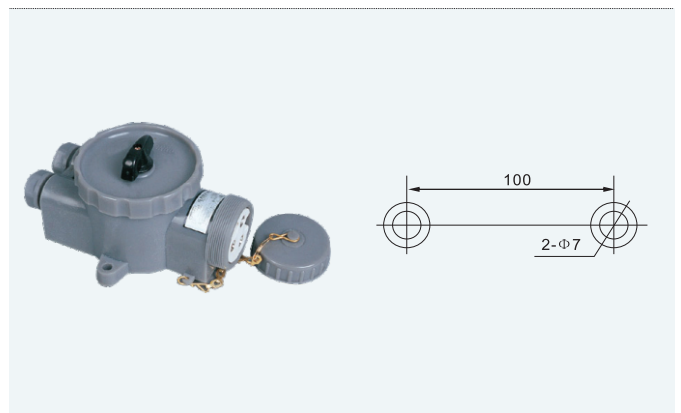





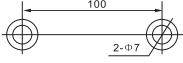

船用尼龙水密插头、插座及开关、接线盒
MARINE NYLON WATERTIGHT PLUG, SOCKET, SWITCH AND JUNCTION BOX

电压Voltage:250V

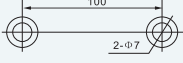
防护等级Protection class : IP56

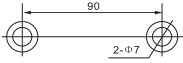
电缆外径Outside diameter: $\phi 14-\phi 16$

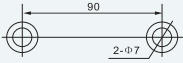
		型号Type	HF2-2
		额定电压Rated Voltage	250V
		重量Weght	HF3-1
		型号Type	250V
		额定电压Rated Voltage	HF4-1
		重量Weght	250V
		型号Type	JXF4-1、JXF4-3
		重量Weght	250V
		接线板形式Connection Plank	
		型号Type	JXF4-2
		重量Weght	250V
		接线板形式Connection Plank	