

10A船用尼龙开关带插座 10A MARINE NYLON SWITCH SWITCH

防护等级: IP56
 电缆外径: $\phi 14-\phi 16$
 Protection class: IP56
 Cable outside Diameter: $\phi 14-\phi 16$



技术特性:

1. 供舰船交直流低电压电器线路连接、接通与分断电路用;
2. 插头单极拔出应为 $\geq 4N$;
3. 导电部分的温升不超过40K;
4. 外表有可靠接地装置;
5. 盖板螺丝为M6防松螺钉。

产品认证

1. 通过欧共体CE认证;
2. 通过中国船级社'CCS'认证。

采用标准

DIN89263

Technical characteristic

1. Used for connecting cutting on or off the appliance circuit with AC or DC low-voltage.
2. The single pole of plug pulled out should be not less than 4N.
3. The temperature rise of conductive part should don't exceed 40K.
4. The shell should have reliable earthing device.
5. The screw of cover plate is M6 locking screw.

Production authentication

1. Approved by CE.
2. Approved by CCS(China Classification Society).

Adopt standard

DIN89263

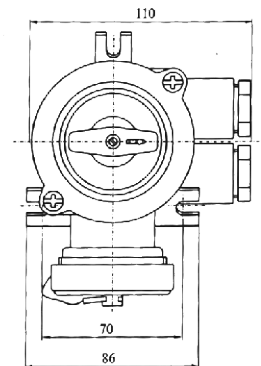
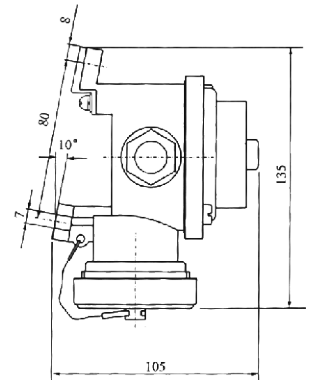

插销示意图 Plug pin diagram						
	电压 Voltage	24V	125V	250V	380V/440V	380V/440V
	代号 Code	1144/FS				
-O	型号 Type	CZKS101-1	CZKS101-2	CZKS101-3	CZKS101-4	CZKS101-5
	重量 Weight	0.35kg	0.35kg	0.35kg	0.35kg	0.35kg
	代号 Code	1144/R/FS				
O-	型号 Type	CZKS109-1	CZKS109-2	CZKS109-3	CZKS109-4	CZKS109-5
	重量 Weight	0.35kg	0.35kg	0.35kg	0.35kg	0.35kg
	代号 Code	1144/D/FS				
-O-	型号 Type	CZKS201-1	CZKS201-2	CZKS201-3	CZKS201-4	CZKS201-5
	重量 Weight	0.37kg	0.37kg	0.37kg	0.37kg	0.37kg
	代号 Code	1144/2/FS				
=O	型号 Type	CZKS202-1	CZKS202-2	CZKS202-3	CZKS202-4	CZKS202-5
	重量 Weight	0.37kg	0.37kg	0.37kg	0.37kg	0.37kg
	代号 Code	1144/2/R/FS				
O=	型号 Type	CZKS209-1	CZKS209-2	CZKS209-3	CZKS209-4	CZKS209-5
	重量 Weight	0.37kg	0.37kg	0.37kg	0.37kg	0.37kg