

IEC船用防水插头 IEC MARINE WATERTIGHT PLUG

额定电压Rating voltage: AC100-130V, AC200-250V, AC380-415V, AC440-460V
 防护等级Protection class : IP56
 采用标准Adopted standard : DIN89270

IMPA CODE	792751
-----------	--------

参数Specificateion	W.T.2P+EarthPlug,100-130V,Yellow
------------------	----------------------------------

类型Type	⊕ Offset Angle
--------	----------------

型号Type	P12-2B
--------	--------

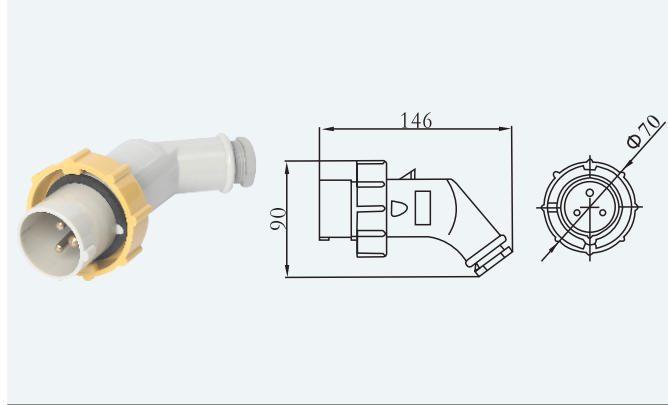

IMPA CODE	792752
-----------	--------

参数Specificateion	W.T.2P+EarthPlug,200-250V,Blue
------------------	--------------------------------

类型Type	⊕ Offset Angle
--------	----------------

型号Type	P12-2B
--------	--------

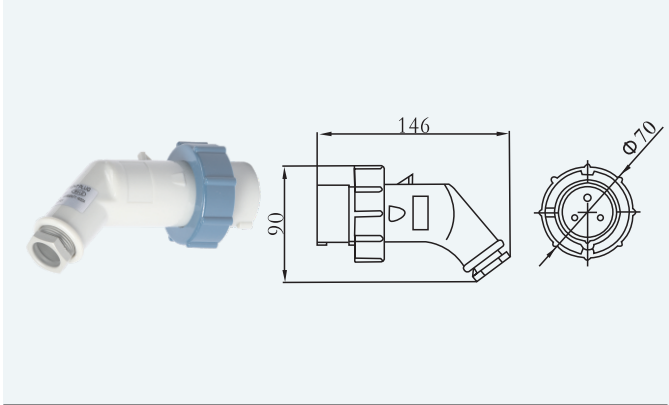

IMPA CODE	792753
-----------	--------

参数Specificateion	W.T.2P+EarthPlug,200-250V,Blue
------------------	--------------------------------

类型Type	⊕ Offset Angle
--------	----------------

型号Type	P12-3B
--------	--------

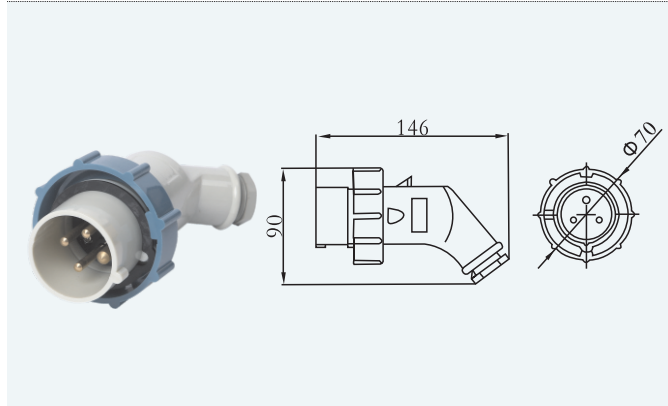

IMPA CODE	792754
-----------	--------

参数Specificateion	W.T.2P+EarthPlug,380-415V,Red
------------------	-------------------------------

类型Type	⊕ Offset Angle
--------	----------------

型号Type	P12-3B
--------	--------

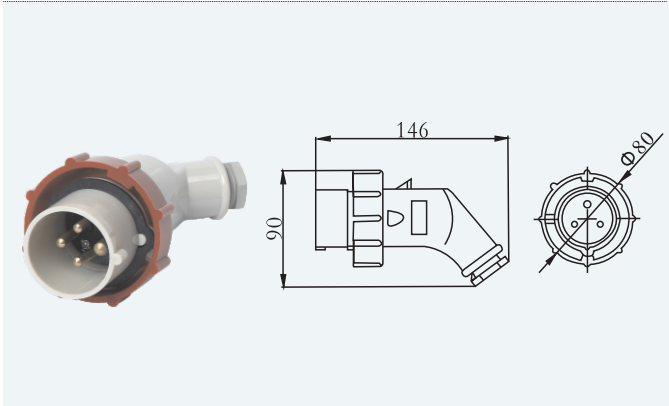

IEC船用防水插头 IEC MARINE WATERTIGHT PLUG

额定电压Rating voltage: AC100-130V, AC200-250V, AC380-415V, AC440-460V
 防护等级Protection class: IP56
 采用标准Adopted standard: DIN89270

电气
接插件
Electric
Connectors

IMPA CODE	792755
-----------	--------

参数Specification W.T 2P+Earth Plug AC100-130V, Yellow

类型Type	⊕ Right Angle
--------	---------------

型号Type P12-2B1

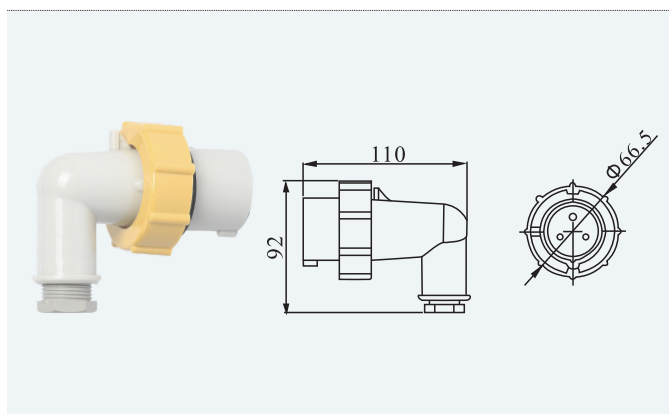

IMPA CODE	792756
-----------	--------

参数Specification W.T.2P+Earth Plug, 200-250V, Blue

类型Type	⊕ Right Angle
--------	---------------

型号Type P12-2B1

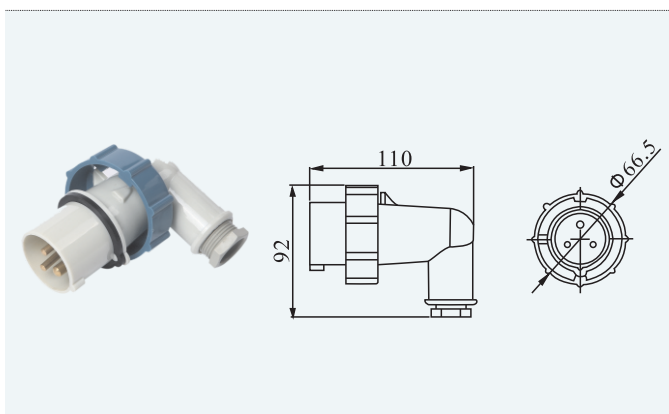

IMPA CODE	792757
-----------	--------

参数Specification W.T.3P+Earth Plug, 200-250V, Blue

类型Type	⊕ Right Angle
--------	---------------

型号Type P12-3B1

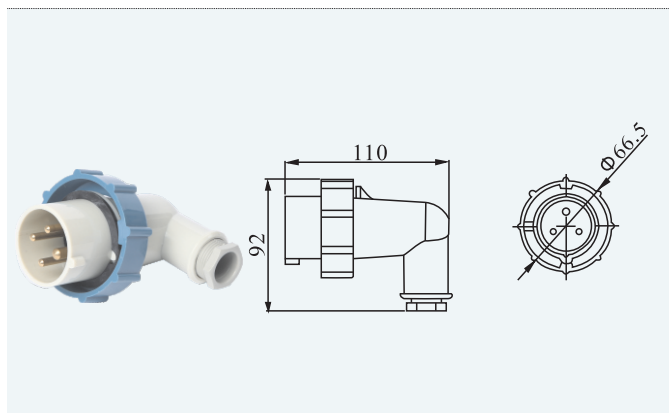

IMPA CODE	792758
-----------	--------

参数Specification W.T 3P+Earth Plug AC380-415V/ AC440-460V Red

类型Type	⊕ Right Angle
--------	---------------

型号Type P12-3B1

